

SW14.5TI

INTEGRAL HYDRAULIC FLANGE SPREADING WEDGE

Repair Manual



EQUALIZER[™]
INTERNATIONAL

info@equalizerinternational.com
www.equalizerinternational.com

INNOVATION IN ITS MOST FUNCTIONAL FORM

INDEX

SECTION	CONTENTS	PAGE NO.
1	INTRODUCTION	1
2	TROUBLESHOOTING	2
3	SPARE PARTS	3-6
4	CLEARING AIR VENT OBSTRUCTIONS	7
5	CLOSING THE RELEASE VALVE	7
6	SERVICING THE INTERMEDIATE & OUTLET CHECK VALVES	8-9
7	OIL LEAKING FROM RESERVOIR AIR VENT	10
8	DISMANTLING THE PUMP	10-12
9	REMOVING THE WEDGEHEAD	13-14
10	SERVICING THE PISTON ROD ASSEMBLY	15-17
11	BLEEDING THE SYSTEM	18-22

1. INTRODUCTION

The Equalizer SW14.5TI Integral Hydraulic Flange Spreading Wedge Repair Manual will enable a technician to locate problems and to carry out the necessary repairs with ease.

Each example is illustrated with 3D images to assist in identifying the parts along with step by step instructions ensuring that the technician can repair the tool with confidence.

The use of these instructions will promote safe use and maximize the service life of the tool.

It is recommended that all sections of this repair manual are read prior to carrying out any repairs to the tool.

2. TROUBLESHOOTING

Problem: Wedge advances 50% and then stops functioning

- ↪ A sticker has been placed over the air vent ↪ Remove sticker ↪ see section 4
- ↪ The operator is covering the air vent with his finger while operating the pump ↪ One hand should be on the handle of the tool while the other hand operates the pump handle ↪ see section 4
- ↪ The air vent has become blocked with dirt ↪ Carefully unblock the air vent using a small blunt object ↪ see section 4

Problem: No wedge movement

- ↪ Air lock within system ↪ Open release valve and prime pump to circulate oil around the system
- ↪ Insufficient oil ↪ Refill with clean oil and bleed system ↪ see section 11
- ↪ Release valve open ↪ Close release valve ↪ see section 5
- ↪ Air accumulates around pump inlet when used upside down ↪ Bleed out air from reservoir. Look for any oil leaks on reservoir which may indicate a perished bladder ↪ see section 11
- ↪ Inlet check or intermediate valve ball stuck ↪ Dismantle check valve, free and clean balls ↪ see section 6

Problem: Wedge moves but under load feels as if it is not reaching full pressure

- ↪ Intermediate valve not seating / relief valve leaking ↪ Check ball for dirt then re-seat using a hammer and punch ↪ see section 6

Problem: Pressure leaks away, handle rises of its own accord

- ↪ Outlet check valve leaking ↪ Check ball for dirt then re-seat using a hammer and punch ↪ see section 6

Problem: Pressure leaks away, handle remains static

- ↪ Release valve leaking ↪ Release lever may not be tight enough
- ↪ Piston seal leaking ↪ Look for oil leaking from cylinder bearing
- ↪ Leaks on cylinder or pump body ↪ Check blanking plugs for leaks, tighten

Problem: Spongy action

- ↪ Air in system ↪ Bleed system ↪ see section 11



3. SPARE PARTS

SW14.5TI WEDGEHEAD

ITEM	PART No.	DESCRIPTION	QUANTITY
01	300203-02	JAWS	01 set of 2
02	300101-01	WEDGE	01 each
03	301301-01	GRUB SCREW	01 each
04	301201-08	ROLL PINS	01 set of 8
05	301102-01	BODY	01 each
06	300301-01	CONNECTOR/PUSH ROD	01 each
07	300501-04	SLIDE PINS	01 set of 4
08	401801-01	RETAINING SCREW	01 each
09	308201-01	HANDLE	01 each
10	312301-01	HANDLE SLEEVE	01 each
11	310601-01	GREASE NIPPLE	01 each
12	311601-02	RING	01 set of 2
13	300401-04	GRUB SCREWS	01 set of 4

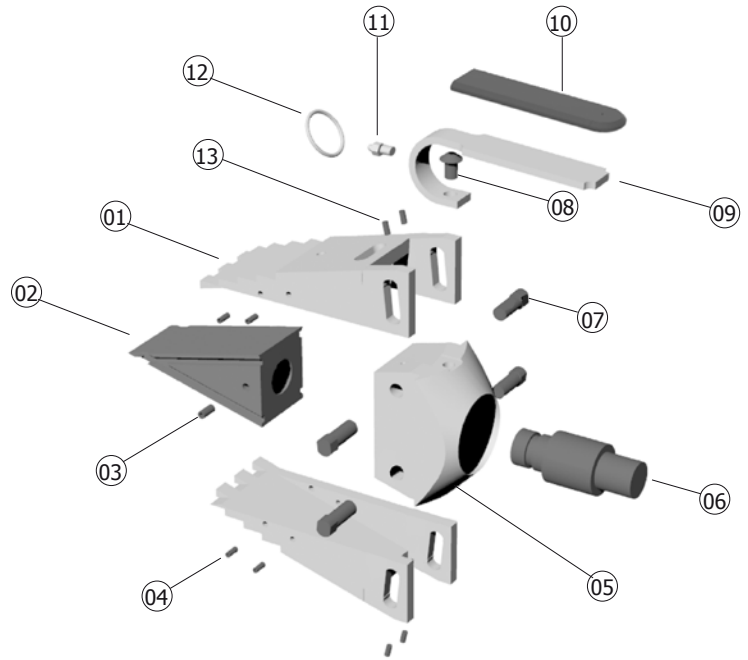

INTEGRAL HYDRAULIC PUMP/CYLINDER

A variety of pump/cylinder units are supplied with the SW14.5TI kit. The pump/cylinder unit supplied with the kit being used can be determined by the serial number etched into the pump body.

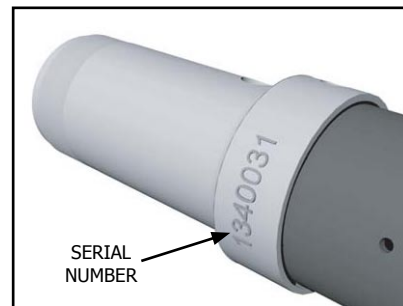

Serial number	Pump/cylinder type
1340000 to 1340031	Single speed
1340032 to 1340292	Dual speed
1340293 onwards	Dual or single speed (as above) with upgraded piston rod and seal

SINGLE SPEED PUMP/CYLINDER (serial no. 1340000 to 1340031)

ITEM	PART NO	DESCRIPTION	QUANTITY
01	303401-01	BEARING	01
02	303801-01	SEAL	01
03	303901-01	PUMP BODY OUTLET &	01
04	310901-01	INTERMEDIATE CHECK VALVE (KIT)	01 kit
05	303502-01	PISTON ROD / SPRING ASSY (KIT)	01 kit

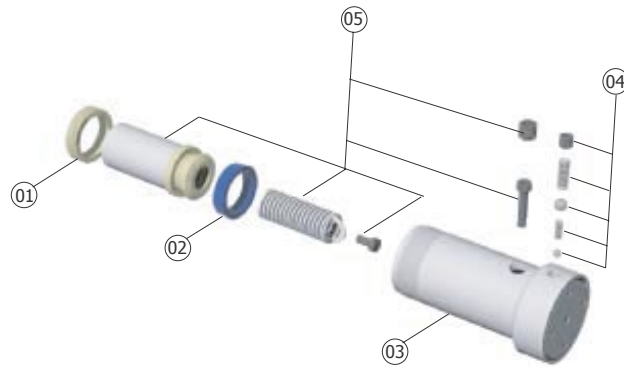

ITEM	PART NO	DESCRIPTION	QUANTITY
01	304001-01	FILTER	01 ea
01	310701-01	BARREL RELIEF VALVE ASSY	01 kit

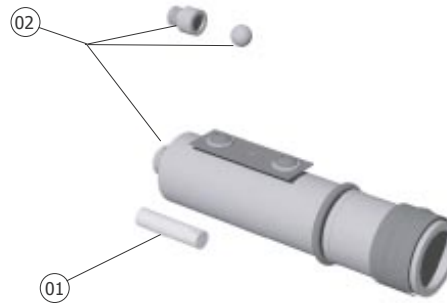

ITEM	PART NO	DESCRIPTION	QUANTITY
01	304501-01	BELLOWS	01 ea
02	304601-01	RESERVOIR	01 ea
03	304801-01	END CAP	01 ea
04	311001-01	SERVICE KIT (END CAP)	01 kit
05	306001-01	SPRINGL PIN	01 ea
06	306101-01	PISTON ROD	01 ea
07	306201-01	BEARING	01 ea
08	306301-01	PIVOT PLATE	01 ea
09	305701-01	LINK	01 ea
10	306501-01	HANDLE SLEEVE	01 ea
11	306401-01	HANDLE	01 ea

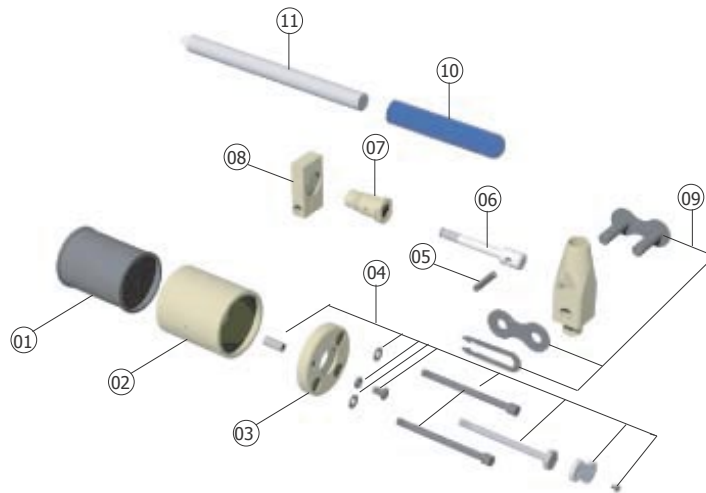



DUAL SPEED PUMP/CYLINDER (serial no. 1340032 to 1340292)

ITEM	PART NO.	DESCRIPTION	QUANTITY
01	303401-01	BEARING	01 ea
02	303501-01	PISTON ROD	01 ea
03*	303801-01	SEAL	01 ea
04	303601-01	SPRING	01 ea
05	303701-01	SKT CAP SCREW	01 ea
06	303901-01	PUMP BODY	01 ea
07*	307301-01	BALL	01 ea
08*	314901-01	SPRING	01 ea
09*	307501-01	BALL	01 ea
10*	307601-01	SPRING	01 ea
11	307701-01	SOCKET PLUG	01 ea
12	307801-01	SOCKET PLUG	01 ea
13	307901-01	SKT CAP SCREW	01 ea

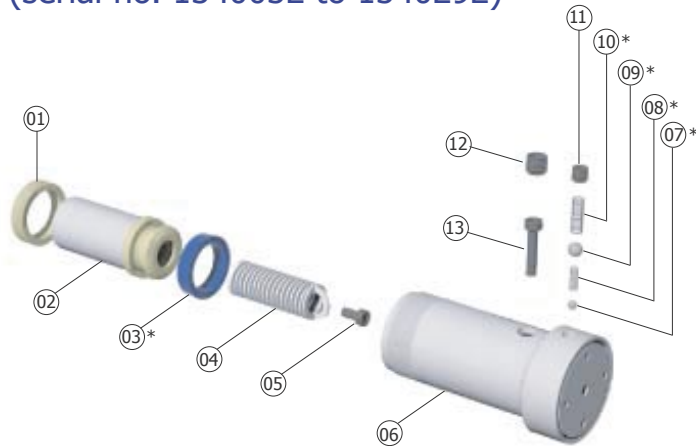

ITEM	PART NO	DESCRIPTION	QUANTITY
01*	308401-01	"O" RING	01 ea
02	308501-01	CONNECTOR TUBE	01 ea
03*	308601-01	"O" RING	01 ea
04*	306601-01	BALL	01 ea
05	306901-01	RELEASE BODY	01 ea
06	310801-01	BARREL RELIEF VALVE ASSY	01 ea
07	306701-01	DOWAL	01 ea
08	306802-01	CLIP	01 ea
09*	308701-02	"O" RING	01 set of 2
10*	308801-01	"O" RING	01 ea
11*	308901-01	BACK UP RING	01 ea

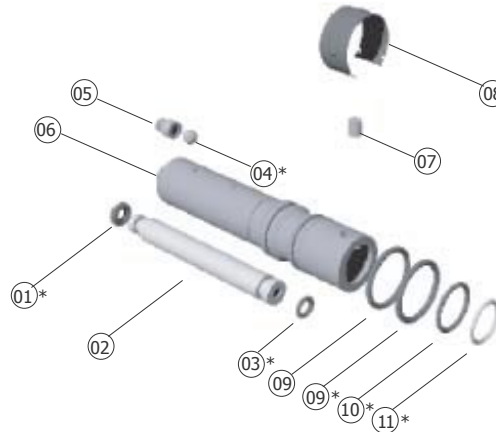

ITEM	PART NO	DESCRIPTION	QUANTITY
01*	304501-01	BELLOWS	01 ea
02	304601-01	RESERVOIR	01 ea
03	309101-01	ADJUSTING SCREW	01 ea
04	304701-01	RELEASE SLEEVE	01 ea
05*	309001-01	SPRING	01 ea
06*	306601-01	BALL	01 ea
07	309201-01	END CAP	01 ea
08*	305001-02	BONDED WASHER	01 set of 2
09	305101-02	SKT BTN SCREW	01 set of 2
10*	305201-02	COPPER WASHER	01 set of 2
11	309301-02	SKT CAP SCREW	01 set of 2
12	305601-01	RETAINING SCREW	01 ea
13	305501-01	RELEASE LEVER	01 ea
14	309401-01	RELEASE SCREW	01 ea
15	304901-01	WASHER	01 ea
16*	309501-01	"O"RING	01 ea
17	309601-01	SPRING	01 ea
18	307301-01	BALL	01 ea
19	309701-01	INLET FITTING	01 ea
20	309801-01	FILTER ELEMENT	01 ea
21	305801-01	CLEVIS	01 ea
22	306001-01	SPRING PIN	01 ea
23	305701-01	LINK	01 ea
24	309901-01	PISTON ROD	01 ea
25*	310101-01	BACK-UP RING	01 ea
26	308601-01	"O" RING	01 ea
27	310201-01	BEARING	01 ea
28	306301-01	PIVOT PLATE	01 ea
29	306501-01	HANDLE SLEEVE	01 ea
30	306401-01	HANDLE	01 ea

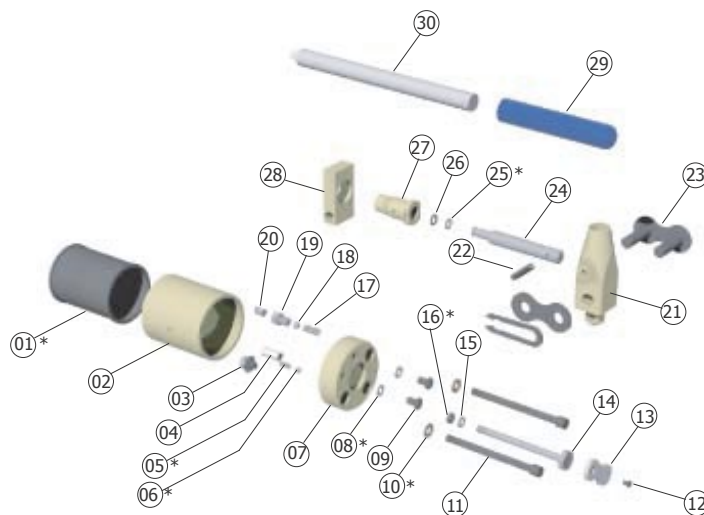

Items marked * are also available as part of a service kit (part no. 308001) which will service all pump models

PUMP/CYLINDER WITH UPGRADED PISTON ROD AND SEAL
 (serial no. 1340293 onwards)

ITEM	PART NO	DESCRIPTION	QUANTITY
01	303503-01	PISTON ROD	01 ea
02*	303802-01	SEAL	01 ea

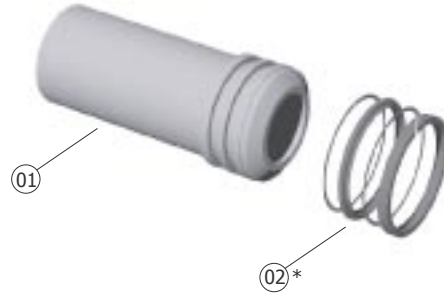

Items marked * are also available as part of a service kit (part no. 308001) which will service all pump models

4. CLEARING AIR VENT OBSTRUCTIONS

Ensure that the air vent on the side of the reservoir is free from any obstruction such as dirt, or in some cases a sticker which the customer may have placed over it.

The air vent allows the bellows to collapse as the wedge is advanced and to expand as the wedge retracts.

If the air vent is obstructed in any way a vacuum will occur and the wedge will not advance properly.

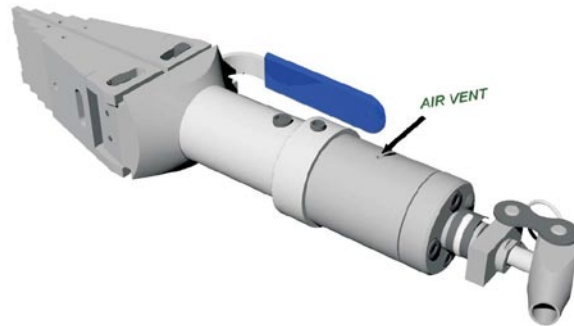

5. CLOSING THE RELEASE VALVE

If the wedge does not advance at all, it may be because the release valve has not been closed properly.

Turn the release valve in a clockwise direction to close.



6. SERVICING THE INTERMEDIATE & OUTLET CHECK VALVES

1. Using a 3/16" hex key remove the socket plug.

Remove the outlet spring, outlet check valve, intermediate spring and intermediate check valve.

Examine both check valves for damage or dirt and examine inside the hole for dirt or damage to the valve seats.

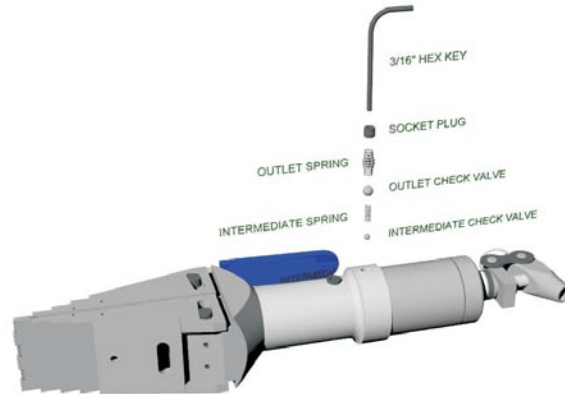

2. If no damage is present, and once any dirt has been removed, place the intermediate check valve back into the hole and ensure it is positioned correctly at the bottom of the hole.

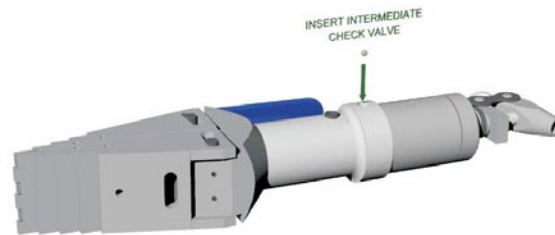

3. Place a 5mm flat punch in top of the check valve and hold firmly with one hand. Ensure that the punch is held vertically and, using a hammer, apply one firm blow to the punch.

This will ensure that the intermediate check valve has been sealed properly into the seat and that it will hold pressure under load.

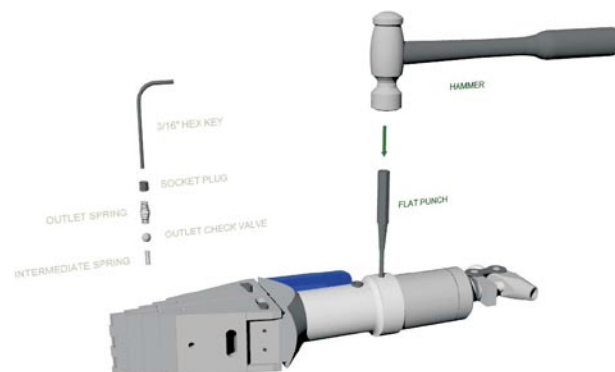

- 4.** Next insert the intermediate spring and outlet check valve.

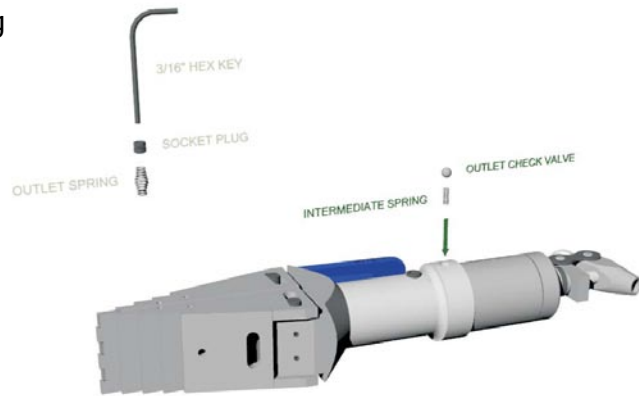

- 5.** Place an 8 mm flat punch on top of the check valve and hold firmly with one hand. Ensure that the punch is held vertically and, using a hammer, apply one firm blow to the punch.

This will ensure that the outlet check valve has been sealed properly into the seat and that it will hold pressure under load.

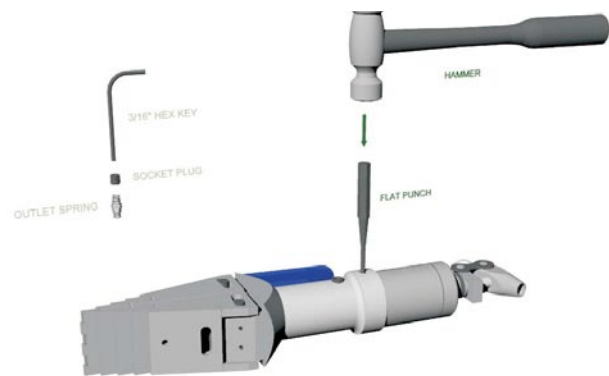

- 6.** At this stage it is advised to fill the hole up with some hydraulic oil. This will, in most cases, avoid having to bleed any air out of the system once the socket plug is re-inserted.

Insert the outlet spring.

Apply PTFE tape or a thread sealer around the socket plug thread and re-insert.

Tighten using the 3/16" hex key.

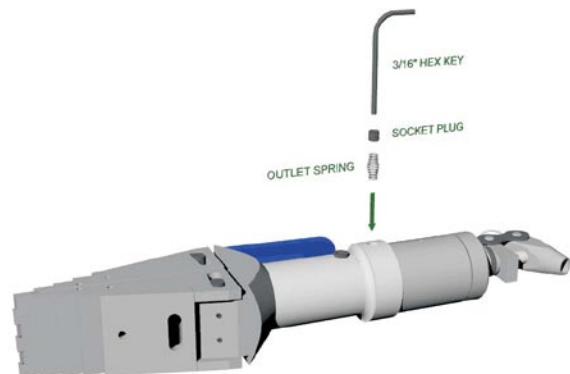

The tool should now be tested for proper function and to ensure that no air is present with the unit.

Advance the wedge fully out until pressure is reached at the end of the stroke. If pressure cannot be reached more oil will have to be added to the system (see section 11).

7. OIL LEAKING FROM RESERVOIR AIR VENT

If oil is leaking from the air vent, this means that the bellows within have been punctured and must be replaced (see section 8).

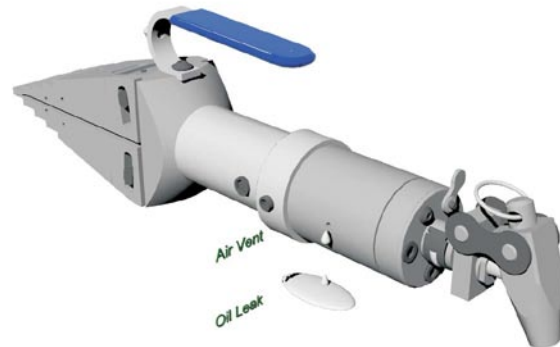

8. DISMANTLING THE PUMP

1. Remove clip and link.



2. Once the link has been removed, the piston rod can be pulled out.

At this stage the seal ("O" ring) and back-up ring can be examined and replaced if necessary.

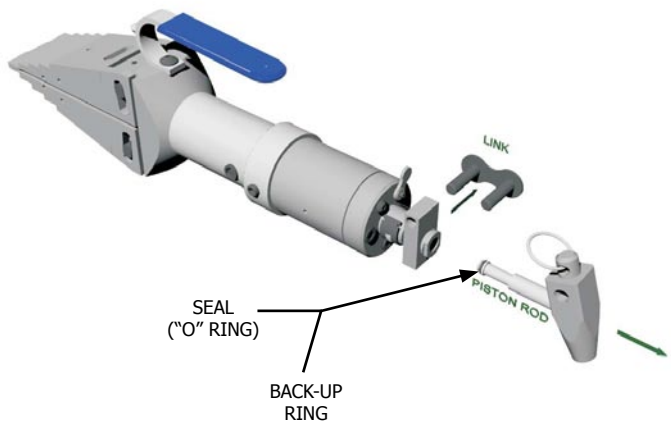

- 3.** Remove the spring clip and dowel.

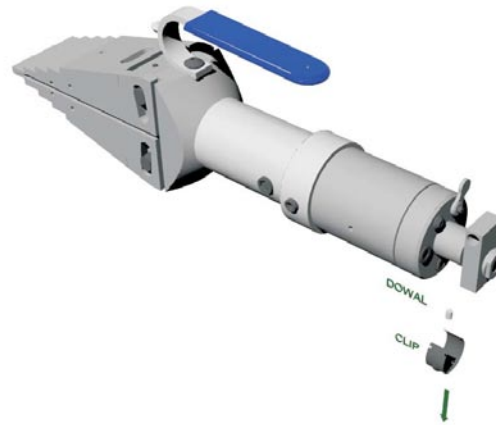

- 4.** Unscrew the bearing and slide the pivot plate off.

Examine and remove the back-up ring and "O" ring from within the barrel relief valve assembly.

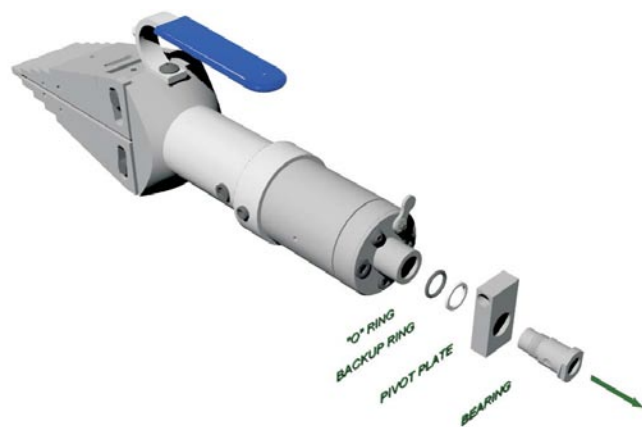

- 5.** Remove the release lever and unscrew the release screw but do not remove.

Unscrew and remove both socket cap screws and copper washers.

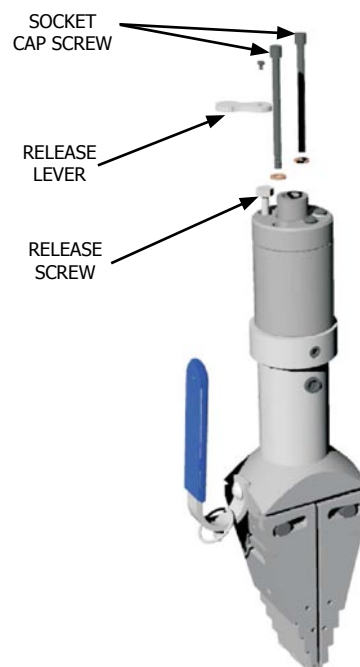

- 6.** Hold the reservoir firmly when removing the end cap to prevent hydraulic oil from escaping.

Once the end cap is removed, tilt the pump over and empty the oil into a container.

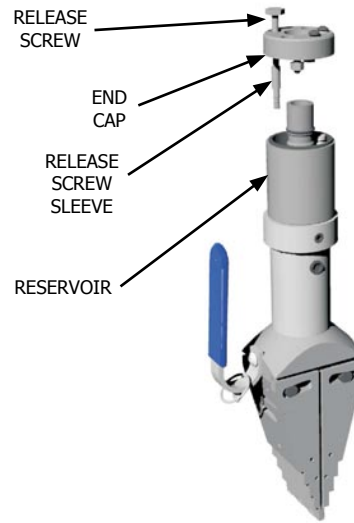

- 7.** With the hydraulic oil removed, stand the pump upright again and remove the reservoir and bellows.



- 8.** Remove all three "O" rings.

Note: when re-assembling the pump ensure that the release valve is placed into the release body and the pump remains upright during assembly.

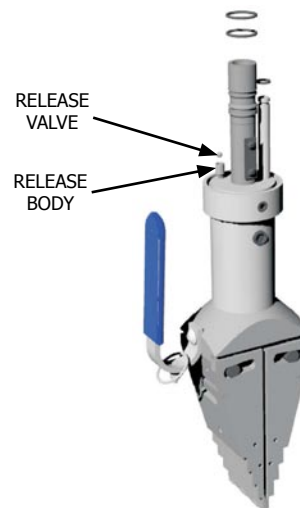

9. REMOVING THE WEDGEHEAD

- 1.** Unscrew and remove all four grub screws.

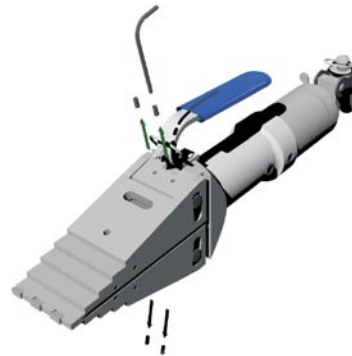

- 2.** Remove all four slide pins.

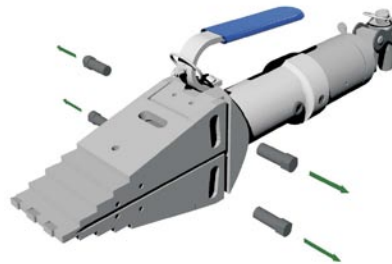

- 3.** Advance the wedge forward 25 mm (1").



- 4.** Remove the M6 x 12 mm grub screw from the wedge.

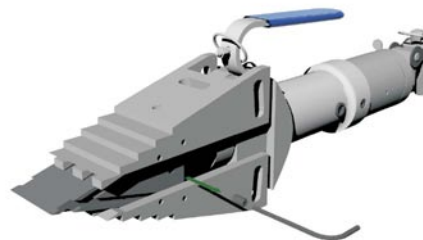

-
- 5.** The wedge and jaws can now be removed from the body / push pin.

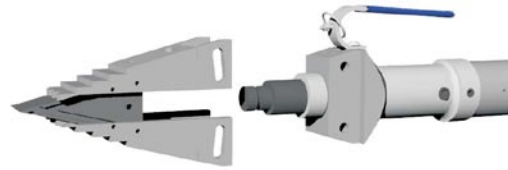

-
- 6.** The body is secured to the pump using loctite thread sealer and will need to be heated in order to release the hold.

To remove the body from the pump, a blow lamp will be required to apply an evenly spread heat around the body area. The body should be heated to approximately 120°C.

It is important to make sure that the piston rod is fully retracted within the pump so that minimum heat will reach through and damage the seal.

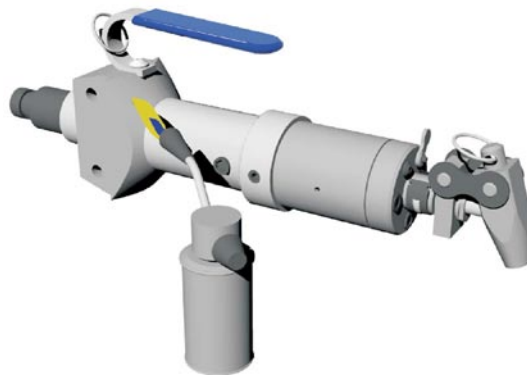

-
- 7.** The pump should be held in a vice and the body can then be unscrewed using a monkey wrench or stillson.

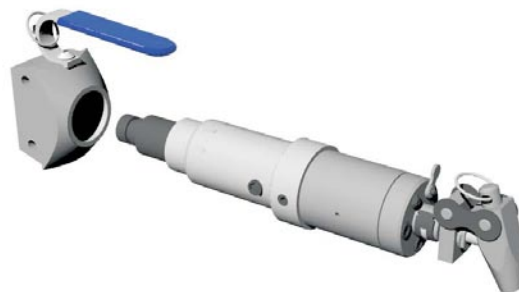

10. SERVICING THE PISTON ROD ASSEMBLY

1. With the piston rod fully retracted place the pump in a vice to hold it firmly.

Unscrew and remove the socket plug using a 1/4" hex key.

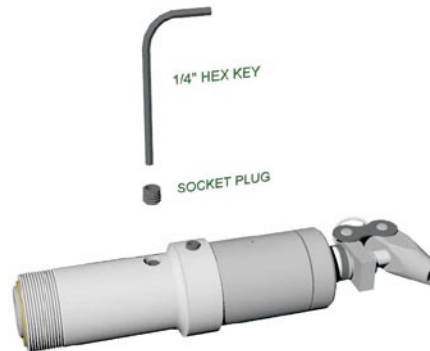

2. Using an M5 hex key unscrew and remove the socket cap screw.

This will release the piston rod return spring within the pump.

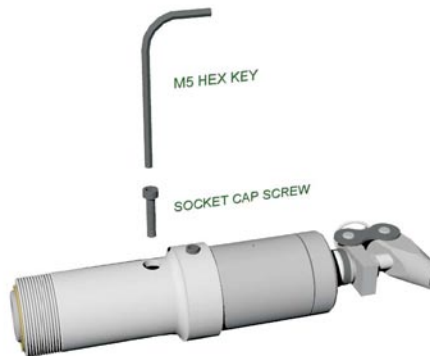

3. Unscrew the bearing anti-clockwise using a small flat punch and hammer.



4. Remove the piston rod, seal and spring.



- Remove the first back-up ring then the seal followed by the second back-up seal and finally the wiper seal.

This sequence should be followed in reverse when re-assembling.



- Ensure that the spring is inserted at 90 degrees to the socket cap screw as it is placed into the pump.

NOTE: great care MUST be taken to ensure that the back up rings remain in position as the piston rod assembly is re-inserted into the pump. This will prevent leakage when assembled.

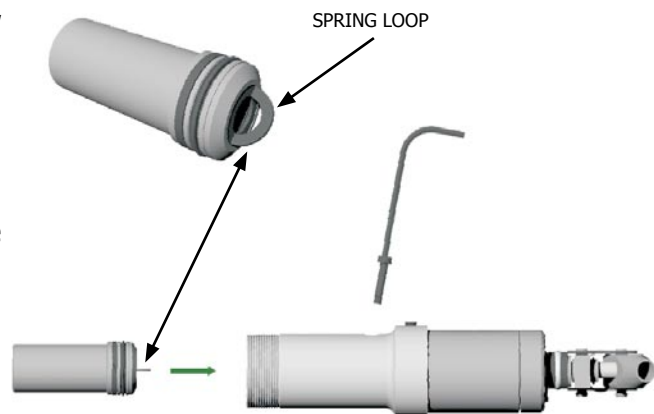

- Insert the piston rod, spring and seal fully into the pump.

Using the M5 hex key tilt the socket cap screw at 10 degrees and place into the hole and through the loop of the spring.



- Screw the socket cap screw at this angle through the spring until it will screw no further.



-
- 9.** Tilt the socket cap screw upright which in turn will pre-load the spring.

Now locate the socket cap screw into the threaded hole and carry on screwing until it is fully tight.

This procedure requires some control as the load of the spring must be retained at the same time as the screw is turned, ensuring that the screw locates into the thread correctly.

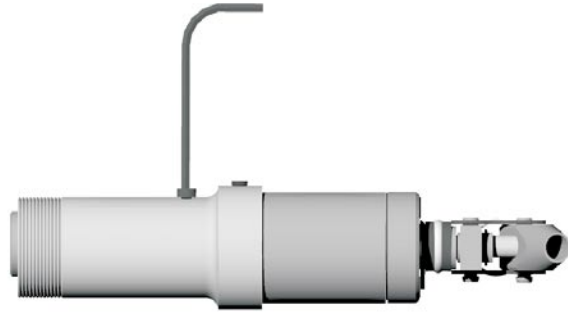

-
- 10.** Apply some thread sealing tape to the thread of the socket plug and then using the 1/4" hex key insert and tighten the socket plug.

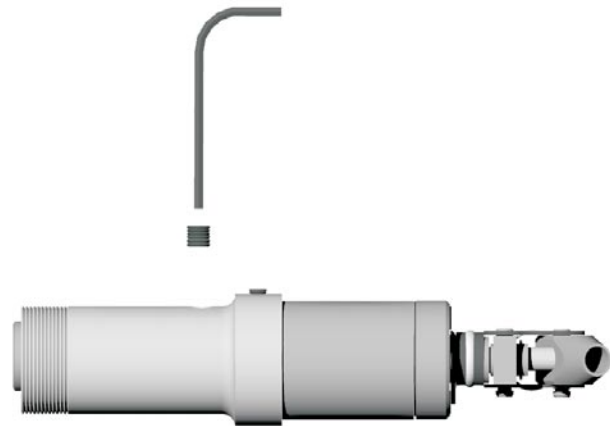

11. BLEEDING THE SYSTEM

1. Place the tool in an upright position



2. Loosen and remove the button-head screw which has the copper washer.

This screw is the one situated on the right hand side of the two as shown. This is the oil reservoir filler point and bleed screw.

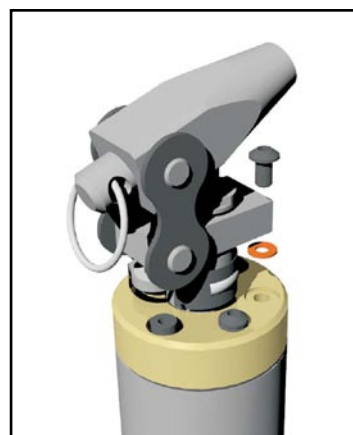

3. Use an oil can which has been cleaned and filled with hydraulic oil (Grade 32 centi).

Place the nozzle of the oil can into the filler hole and pump hydraulic oil into the reservoir. This should be done in stages by removing the nozzle frequently allowing trapped air to escape out of the bleed hole.

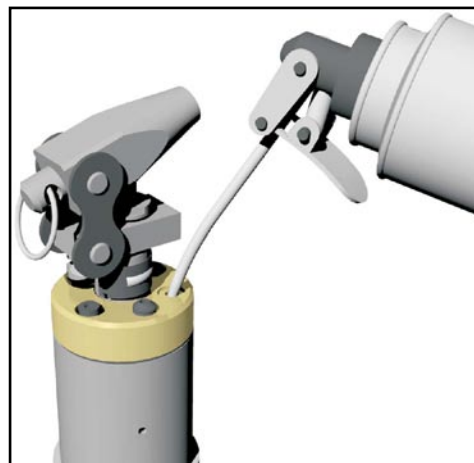

- 4.** Continue filling in this manner until the hydraulic oil is over-flowing.

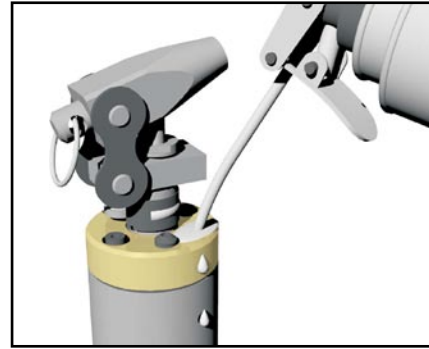

- 5.** Close the release lever in a clockwise direction.

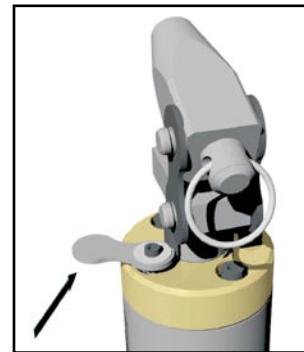

- 6.** Prime the pump and advance the wedge forward.

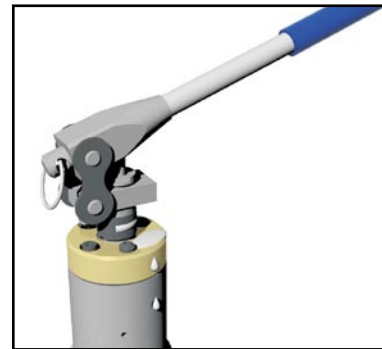

- 7.** Continue priming until the wedge is fully advanced.



- 8.** Add some more hydraulic oil until it over-flows again.



- 9.** Open the release lever slowly allowing the wedge to retract. As the wedge retracts hydraulic oil and air bubbles will over-flow out of the filler hole.

When all the bubbles have ceased and the oil is clear flowing, this means that the system is free of air.

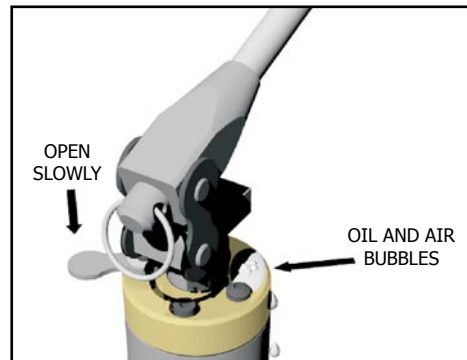

- 10.** Allow the wedge to retract until it is within 10% of being fully retracted, at this point close the release lever to stop the wedge from fully retracting.

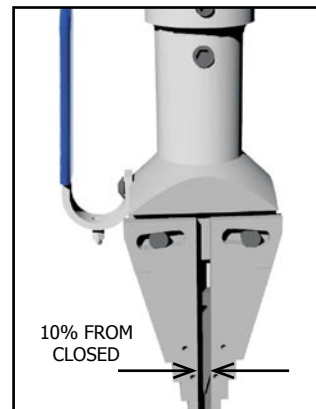

- 11.** With the release lever in the closed position and the hydraulic oil clear of any air bubbles re-insert the copper washer and button head screw and tighten.

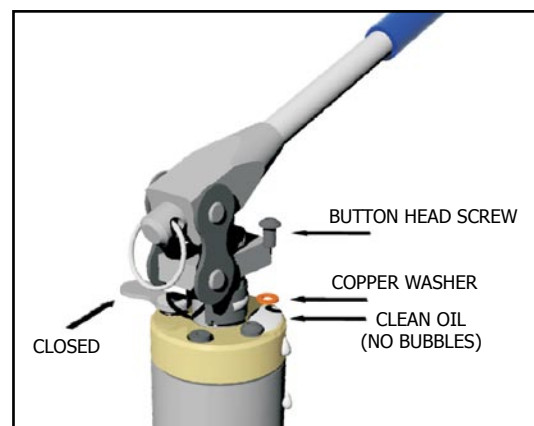

-
- 12.** Open the release lever and allow the wedge to fully retract.

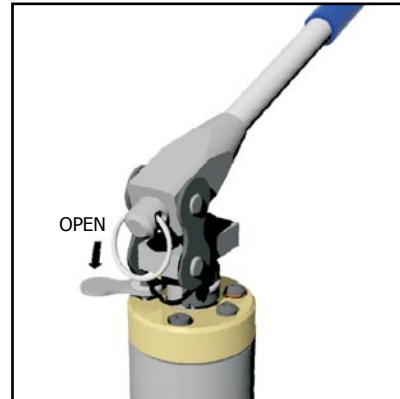

-
- 13.** Check that the wedge has fully retracted and the jaws have closed together.

If the wedge does not fully retract, this indicates that there is too much oil within the system and some should be bled out.

This can be done by loosening the button head screw and allowing a small amount of hydraulic oil to escape until the wedge is closed.



-
- 14.** Close the release lever and prime the wedge open.





-
- 15.** As the wedge opens to its maximum, pressure should start to build up on the handle. If pressure becomes present this means that the system has enough hydraulic oil and the procedure is complete.

If the wedge does not fully advance and pressure is not present, this means that there is insufficient oil within the system and steps 8 to 14 should be repeated.

